

## Product Series 产品系列



### 标配 Standard Configuration

- CURTIS控制器 CURTIS controller
- AC驱动系统 AC Drive system
- 可调式方向盘 Adjustable steering wheel
- 自动控温系统 Automatic temperature control system
- 坡道辅助制动系统 Ramps Auxilliary Brake System
- 安全切断阀 Safety shut-off valve
- LED 警示灯 LED warning lamp
- LED 前大灯 LED headlamp
- 大容量蓄电池 High capacity battery
- 智能充电机 Intelligent charger

### 选配 Options

- 悬浮座椅 Suspension seat
- 侧取式电池 Side take battery
- 人在位感知系统 Operator presence system
- 侧移器 Side shifter
- 纸卷夹等各类属具 Paper roll clamp and other attachments
- 冷库型 Cold storage use
- 防爆型 Explosion-proof use



## 电动平衡重叉车 ELECTRIC COUNTERBALANCE FORKLIFT TRUCK

产品信息表 **PRODUCT SPECIFICATION**

标准 Standard							
1.1	品牌	Brand		Empremaq	Empremaq	Empremaq	Empremaq
1.2	型号	Model		FE15	FE20	FE25	FE30
1.3	动力类型	Power Type		蓄电池Battery	蓄电池Battery	蓄电池Battery	蓄电池Battery
1.4	驾驶方式	Operation Type		坐驾式Seated	坐驾式Seated	坐驾式Seated	坐驾式Seated
1.5	额定载荷	Rated Capacity	Q (kg)	1500	2000	2500	3000
1.6	载荷中心距	Load Center	C (mm)	500	500	500	500
1.7	前悬距	Front Overhang	x (mm)	380	420	425	433
1.8	轴距	Wheelbase	y (mm)	1380	1505	1505	1700
重量 Weight							
2.1	整车重量 (含电池)	Service weight (incl battery)	kg	2900	3380	3820	4370
轮胎 Wheel							
3.1	轮胎类型, 驱动侧/承重侧	Wheel type		充气胎Pneumatic tyre	充气胎Pneumatic tyre	充气胎Pneumatic tyre	充气胎Pneumatic tyre
3.2	轮胎尺寸, 承重侧	Loading wheel	mm	5.00-8	18×7-8	18×7-8	18×7-8
3.3	轮胎尺寸, 驱动侧	Driving wheel	mm	6.00-9	21×8-9	21×8-9	23×9-10
3.4	车轮数量, 前/后(x=驱动轮)	Tyres, front/rear		2x/2	2x/2	2x/2	2x/2
3.5	轮距, 驱动侧	Tread, drive	b10 (mm)	910	950	950	970
3.6	轮距, 承重侧	Tread, load	b11 (mm)	930	960	960	960
尺寸 Dimension							
4.1	门架倾斜范围, 前/后	Mast tilting	α/β(°)	6/10	6/10	6/10	6/10
4.2	门架闭合高度	Height of mast closed	h1 (mm)	1995	1995	1995	2110
4.3	自由起升高度	Full free lift height	h2 (mm)	135	140	145	145
4.4	起升高度	Lifting height	h3 (mm)	3000	3000	3000	3000
4.5	起升时门架最大高度	Height of mast open	h4 (mm)	4030	4030	4030	4256
4.6	护顶架高度	Overhead guard height	h6 (mm)	2100	2100	2100	2130
4.7	座椅高度	Seat height	h7 (mm)	1090	1090	1090	1120
4.8	整车长度	Overall length with forks	L1 (mm)	3205	3410	3410	3620
4.9	至叉面长度	Overall length (without forks)	L2 (mm)	2135	2340	2340	2550
4.10	整车宽度	Overall width	b1 (mm)	1110	1160	1160	1200
4.11	货叉尺寸	Forks size	l/e/s (mm)	1070 /100 /35	1070 /100 /40	1070 /100 /45	1070 /125 /45
4.12	安装等级	Installation class		2A	2A	2A	3A
4.13	货叉架宽度	Width of fork backrest	b3 (mm)	1040	1040	1040	1100
4.14	货叉外侧距	Fork spread	b5 (mm)	222 ~1000	222 ~1000	222 ~1000	250 ~1050
4.15	门架离地间隙	Mast clearance	m1 (mm)	85	85	85	90
4.16	车身离地间隙	Ground clearance	m2 (mm)	100	100	100	100
4.17	直角堆垛通道宽度(托盘1000 x1200) 1200 跨货叉方向	AST (pallet 1000 *1200 mm)	Ast (mm)	3580	3720	3720	3920
4.18	转弯半径	Turning radius	Wa (mm)	2000	2100	2100	2300
性能 Function							
5.1	行驶速度, 满/空载	Driving speed (load/unload)	km/h	10/12	10/12	10/12	10/12
5.2	起升速度, 满/空载	Lifting speed (load/unload)	mm/s	300/480	230/400	230/440	200/340
5.3	下降速度, 满/空载	Lowering speed (load/unload)	mm/s	380/360	420/480	360/480	300/460
5.4	牵引力	Traction	(S2-5min)	/	/	/	/
5.5	最大爬坡能力, 满/空载(S2-5min)	Max. climbing ability	%(tan θ)	14/15	14/15	14/15	14/15
5.6	制动方式	Brake type		液压式Hydraulic	液压式Hydraulic	液压式Hydraulic	液压式Hydraulic
驱动 Driving							
6.1	驱动电机功率(S2-60min)	Driving motor	kw	AC 6.8	AC 6.8	AC 6.8	AC 9.1
6.2	起升电机功率, (S3-15%)	Lifting motor	kw	DC 8.2	DC 8.6	DC 8.6	DC 10
6.3	蓄电池, 电压/额定容量	Battery	V/Ah	48/400	48/490	48/560	48/630
6.4	电池重量	Battery weight	kg	645	750	870	980
6.5	转向系统	Steering system		液压式Hydraulic	液压式Hydraulic	液压式Hydraulic	液压式Hydraulic

标准 Standard							
1.1	品牌	Brand		Empremaq	Empremaq	Empremaq	Empremaq
1.2	型号	Model		FE35	FE40	FE45	FE50
1.3	动力类型	Power Type		蓄电池Battery	蓄电池Battery	蓄电池Battery	蓄电池Battery
1.4	驾驶方式	Operation Type		坐驾式Seated	坐驾式Seated	坐驾式Seated	坐驾式Seated
1.5	额定载荷	Rated Capacity	Q (kg)	3500	4000	4500	4999
1.6	载荷中心距	Load Center	C (mm)	500	500	500	500
1.7	前悬距	Front Overhang	x (mm)	468	468	530	530
1.8	轴距	Wheelbase	y (mm)	1800	1800	2000	2000
重量 Weight							
2.1	整车重量 (含电池)	Service weight (incl battery)	kg	5170	5300	6950	7250
轮胎 Wheel							
3.1	轮胎类型, 驱动侧/承重侧	Wheel type		实心橡胶胎Solid rubber tire	实心橡胶胎Solid rubber tire	实心橡胶胎Solid rubber tire	实心橡胶胎Solid rubber tire
3.2	轮胎尺寸, 承重侧	Loading wheel	mm	18×7-8	18×7-8	21×8-9	21×8-9
3.3	轮胎尺寸, 驱动侧	Driving wheel	mm	23×10-12	23×10-12	250-15	250-15
3.4	车轮数量, 前/后(x=驱动轮)	Tyres, front/rear		2x/2	2x/2	2x/2	2x/2
3.5	轮距, 驱动侧	Tread, drive	b10 (mm)	1080	1080	1206	1206
3.6	轮距, 承重侧	Tread, load	b11 (mm)	990	990	1010	1010
尺寸 Dimension							
4.1	门架倾斜范围, 前/后	Mast tilting	α/β(°)	6/10	6/10	6/11	6/11
4.2	门架闭合高度	Height of mast closed	h1 (mm)	2100	2100	2180	2180
4.3	自由起升高度	Full free lift height	h2 (mm)	150	150	150	150
4.4	起升高度	Lifting height	h3 (mm)	3000	3000	3000	3000
4.5	起升时门架最大高度	Height of mast open	h4 (mm)	4130	4130	4100	4100
4.6	护顶架高度	Overhead guard height	h6 (mm)	2130	2130	2250	2250
4.7	座椅高度	Seat height	h7 (mm)	1140	1140	1230	1230
4.8	整车长度	Overall length with forks	L1 (mm)	3770	3770	4030	4030
4.9	至叉面长度	Overall length (without forks)	L2 (mm)	2700	2700	2960	2960
4.10	整车宽度	Overall width	b1 (mm)	1330	1330	1430 /1350	1430 /1350
4.11	货叉尺寸	Forks size	l/e/s (mm)	1070 /125 /50	1070 /125 /50	1070 /150 /50	1070 /150 /50
4.12	安装等级	Installation class		3A	3A	3A	3A
4.13	货叉架宽度	Width of fork backrest	b3 (mm)	1100	1100	2250	2250
4.14	货叉外侧距	Fork spread	b5 (mm)	250 ~1050	250 ~1050	320 ~1320	320 ~1320
4.15	门架离地间隙	Mast clearance	m1 (mm)	80	80	120	120
4.16	车身离地间隙	Ground clearance	m2 (mm)	120	120	120	120
4.17	直角堆垛通道宽度(托盘1000 x1200) 1200 跨货叉方向	AST (pallet 1000 *1200 mm)	Ast (mm)	4190	4190	4490	4490
4.18	转弯半径	Turning radius	Wa (mm)	2450	2450	2670	2670
性能 Function							
5.1	行驶速度, 满/空载	Driving speed (load/unload)	km/h	10/12	10/12	13/13.5	13/13.5
5.2	起升速度, 满/空载	Lifting speed (load/unload)	mm/s	250/	220/	210/350	210/350
5.3	下降速度, 满/空载	Lowering speed (load/unload)	mm/s	/	/	/	/
5.4	牵引力	Traction	(S2-5min)	/	/	27000	27000
5.5	最大爬坡能力, 满/空载(S2-5min)	Max. climbing ability	%(tan θ)	10/12	10/12	10/12	10/12
5.6	制动方式	Brake type		液压式Hydraulic	液压式Hydraulic	机械液压式Hydraulic	机械液压式Hydraulic
驱动 Driving							
6.1	驱动电机功率(S2-60min)	Driving motor	kw	AC 11.75	AC 11.75	AC 16.6	AC 16.6
6.2	起升电机功率, (S3-15%)	Lifting motor	kw	DC 13	DC 13	AC 15	AC 15
6.3	蓄电池, 电压/额定容量	Battery	V/Ah	80/400	80/450	80/560	80/630
6.4	电池重量	Battery weight	kg	1070	1195	1390	1690
6.5	转向系统	Steering system		液压式Hydraulic	液压式Hydraulic	液压式Hydraulic	液压式Hydraulic

## 产品尺寸 PRODUCT SIZE

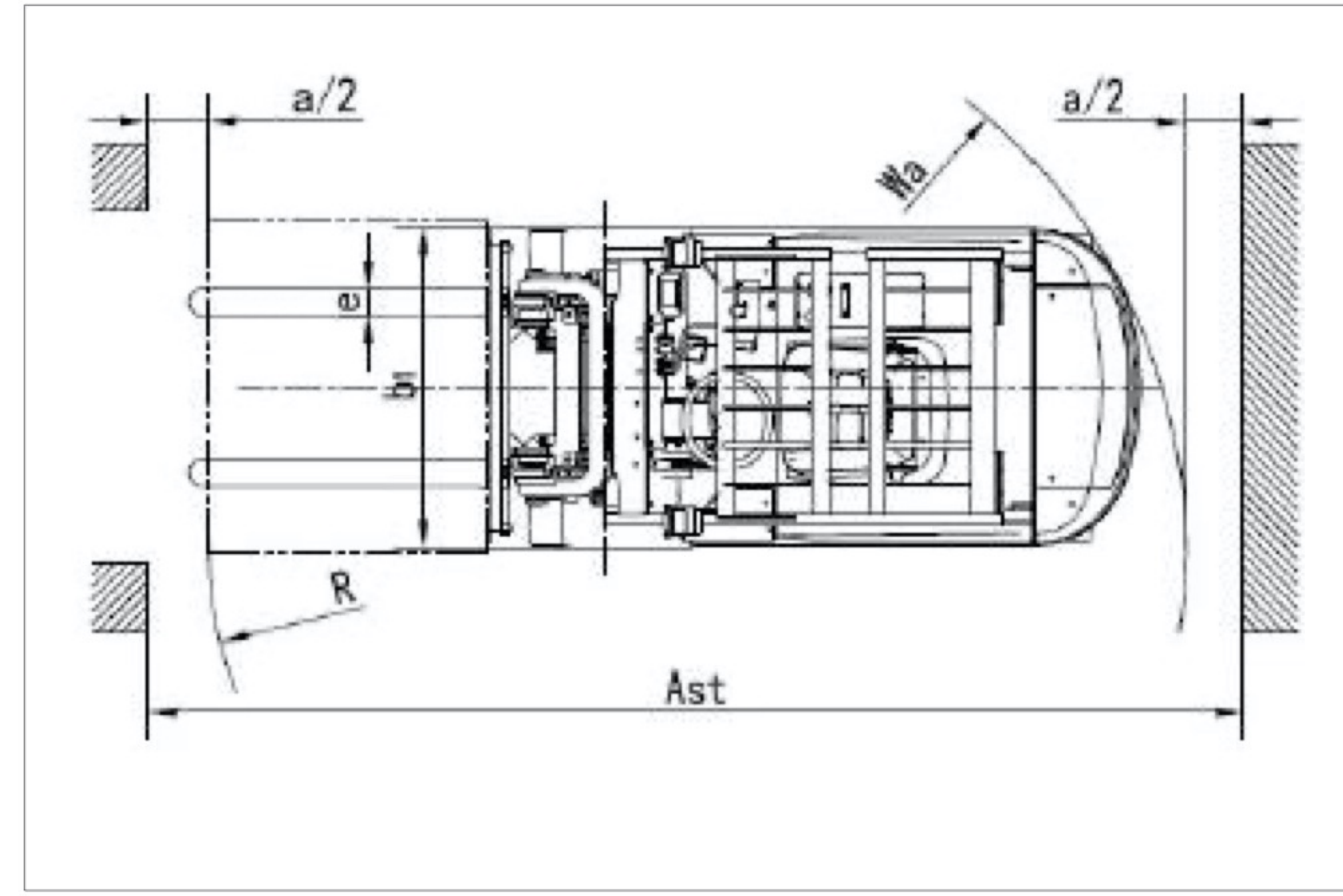
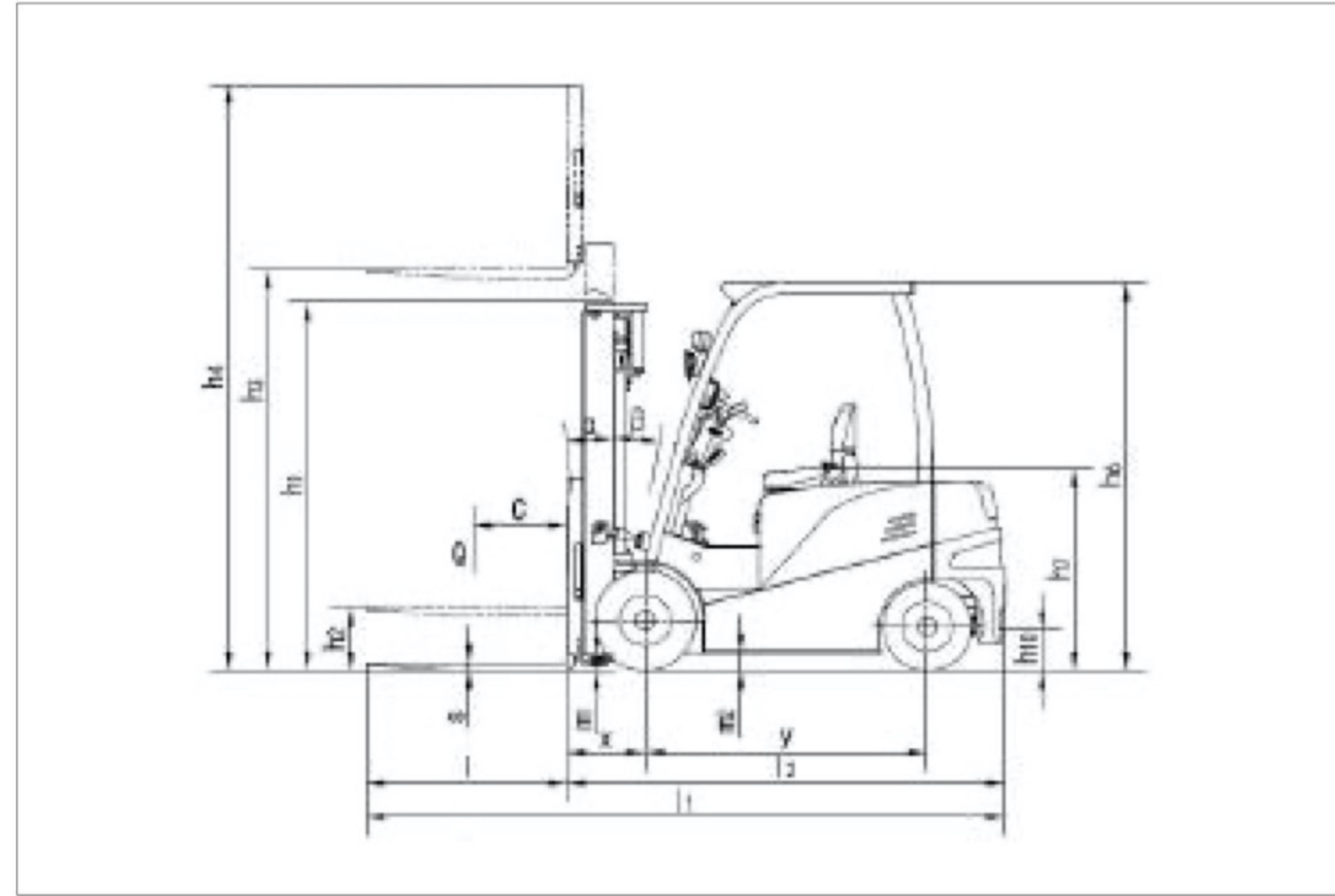

## 门架资料 MAST DATASHEET

门架参数表 The mast Specification						
两节门架 Duplex Mast						
<b>FE15</b>						
型号 Model	MK	15-25	15-30	15-35	15-40	15-45
提升高度 Liftheight	h3 (mm)	2500	3000	3500	4000	4500
起升时门架最大高度 Height-Mast Extended w/Load-Backrest	h4 (mm)	3530	4030	4530	5030	5530
闭合门架高度 Height-Mast Lowered	h1 (mm)	1745	1995	2245	2545	2795
自由起升高度 Height-Free Lift	h2 (mm)	135	135	135	135	135
两节全自由门架 Duplex fullfree Mast						
<b>FE15</b>						
型号 Model	MK	15Q-25	15Q-30	15Q-35	15Q-40	15Q-45
提升高度 Liftheight	h3 (mm)	2500	3000	3500	4000	4500
起升时门架最大高度 Height-Mast Extended w/Load-Backrest	h4 (mm)	3540	4040	4540	5040	5540
闭合门架高度 Height-Mast Lowered	h1 (mm)	1745	1995	2245	2545	2795
自由起升高度 Height-Free Lift	h2 (mm)	702	952	1202	1502	1752
三节全自由门架 Triplex fullfree Mast						
<b>FE15</b>						
型号 Model	MK	15SQ-40	15SQ-45	15SQ-50	15SQ-55	15SQ-60
提升高度 Liftheight	h3 (mm)	4000	4500	5000	5500	6000
起升时门架最大高度 Height-Mast Extended w/Load-Backrest	h4 (mm)	5030	5530	6030	6530	7030
闭合门架高度 Height-Mast Lowered	h1 (mm)	1928	2095	2262	2428	2595
自由起升高度 Height-Free Lift	h2 (mm)	885	1052	1219	1385	1552
门架参数表 The mast Specification						
两节门架 Duplex Mast						
<b>FE20</b>						
型号 Model	MK	20-25	20-30	20-35	20-40	20-45
提升高度 Liftheight	h3 (mm)	2500	3000	3500	4000	4500
起升时门架最大高度 Height-Mast Extended w/Load-Backrest	h4 (mm)	3530	4030	4530	5030	5530
闭合门架高度 Height-Mast Lowered	h1 (mm)	1745	1995	2245	2545	2795
自由起升高度 Height-Free Lift	h2 (mm)	140	140	140	140	140
两节全自由门架 Duplex fullfree Mast						
<b>FE20</b>						
型号 Model	MK	20Q-25	20Q-30	20Q-35	20Q-40	20Q-45
提升高度 Liftheight	h3 (mm)	2500	3000	3500	4000	4500
起升时门架最大高度 Height-Mast Extended w/Load-Backrest	h4 (mm)	3580	4080	4580	5080	5580
闭合门架高度 Height-Mast Lowered	h1 (mm)	1745	1995	2245	2545	2795
自由起升高度 Height-Free Lift	h2 (mm)	702	952	1202	1502	1752
三节全自由门架 Triplex fullfree Mast						
<b>FE20</b>						
型号 Model	MK	20SQ-40	20SQ-45	20SQ-50	20SQ-55	20SQ-60
提升高度 Liftheight	h3 (mm)	4000	4500	5000	5500	6000
起升时门架最大高度 Height-Mast Extended w/Load-Backrest	h4 (mm)	5035	5535	6035	6535	7035
闭合门架高度 Height-Mast Lowered	h1 (mm)	1930	2095	2260	2425	2645
自由起升高度 Height-Free Lift	h2 (mm)	887	1052	1217	1382	1602

门架参数表 The mast Specification						
两节门架 Duplex Mast						
<b>FE30</b>						
型号 Model	MK	30-25	30-30	30-35	30-40	30-45
提升高度 Liftheight	h3 (mm)	2500	3000	3500	4000	4500
起升时门架最大高度 Height-Mast Extended w/Load-Backrest	h4 (mm)	3760	4260	4760	5260	5760
闭合门架高度 Height-Mast Lowered	h1 (mm)	1860	2110	2360	2660	2910
自由起升高度 Height-Free Lift	h2 (mm)	145	145	145	145	145
两节全自由门架 Duplex fullfree Mast						
<b>FE30</b>						
型号 Model	MK	30Q-25	30Q-30	30Q-35	30Q-40	30Q-45
提升高度 Liftheight	h3 (mm)	2500	3000	3500	4000	4500
起升时门架最大高度 Height-Mast Extended w/Load-Backrest	h4 (mm)	3770	4270	4770	5270	5770
闭合门架高度 Height-Mast Lowered	h1 (mm)	1850	2100	2350	2650	2900
自由起升高度 Height-Free Lift	h2 (mm)	716	966	1216	1516	1766
三节全自由门架 Triplex fullfree Mast						
<b>FE30</b>						
型号 Model	MK	30SQ-40	30SQ-45	30SQ-50	30SQ-55	30SQ-60
提升高度 Liftheight	h3 (mm)	4000	4500	5000	5500	6000
起升时门架最大高度 Height-Mast Extended w/Load-Backrest	h4 (mm)	5130	5630	6130	6630	7130
闭合门架高度 Height-Mast Lowered	h1 (mm)	1985	2150	2315	2480	2700
自由起升高度 Height-Free Lift	h2 (mm)	831	996	1161	1326	1546
门架参数表 The mast Specification						
两节门架 Duplex Mast						
<b>FE35</b>						
型号 Model	MK	35-25	35-30	35-35	35-40	35-45
提升高度 Liftheight	h3 (mm)	2500	3000	3500	4000	4500
起升时门架最大高度 Height-Mast Extended w/Load-Backrest	h4 (mm)	3630	4130	4630	5130	5630
闭合门架高度 Height-Mast Lowered	h1 (mm)	1850	2100	2350	2650	2900
自由起升高度 Height-Free Lift	h2 (mm)	150	150	150	150	150
两节全自由门架 Duplex fullfree Mast						
<b>FE35</b>						
型号 Model	MK	35Q-25	35Q-30	35Q-35	35Q-40	35Q-45
提升高度 Liftheight	h3 (mm)	2500	3000	3500	4000	4500
起升时门架最大高度 Height-Mast Extended w/Load-Backrest	h4 (mm)	3635	4135	4635	5135	5635
闭合门架高度 Height-Mast Lowered	h1 (mm)	1850	2100	2350	2650	2900
自由起升高度 Height-Free Lift	h2 (mm)	716	966	1216	1516	1766
三节全自由门架 Triplex fullfree Mast						
<b>FE35</b>						
型号 Model	MK	35SQ-40	35SQ-45	35SQ-50	35SQ-55	35SQ-60
提升高度 Liftheight	h3 (mm)	4000	4500	5000	5500	6000
起升时门架最大高度 Height-Mast Extended w/Load-Backrest	h4 (mm)	5130	5630	6130	6630	7130
闭合门架高度 Height-Mast Lowered	h1 (mm)	1983	2150	2317	2483	2650
自由起升高度 Height-Free Lift	h2 (mm)	829	996	1163	1329	1496
门架参数表 The mast Specification						
两节门架 Duplex Mast						
<b>FE50</b>						
型号 Model	MK	50-25	50-30	50-35	50-40	50-45
提升高度 Liftheight	h3 (mm)	2500	3000	3500	4000	4500
起升时门架最大高度 Height-Mast Extended w/Load-Backrest	h4 (mm)	3600	4100	4600	5100	5600
闭合门架高度 Height-Mast Lowered	h1 (mm)	1930	2180	2430	2730	2980
自由起升高度 Height-Free Lift	h2 (mm)	150	150	150	150	150
两节全自由门架 Duplex fullfree Mast						
<b>FE50</b>						
型号 Model	MK	50Q-25	50Q-30	50Q-35	50Q-40	50Q-45
提升高度 Liftheight	h3 (mm)	2500	3000	3500	4000	4500
起升时门架最大高度 Height-Mast Extended w/Load-Backrest	h4 (mm)	3600	4100	4600	5100	5600
闭合门架高度 Height-Mast Lowered	h1 (mm)	1930	2180	2430	2730	2980
自由起升高度 Height-Free Lift	h2 (mm)	820	1070	1320	1620	1870
三节全自由门架						
<b>FE50</b>						
型号 Model	MK	50SQ-40	50SQ-45	50SQ-50	50SQ-55	50SQ-60
提升高度 Liftheight	h3 (mm)	4000	4500	5000	5500	6000
起升时门架最大高度 Height-Mast Extended w/Load-Backrest	h4 (mm)	5140	5640	6150	6650	7140
闭合门架高度 Height-Mast Lowered	h1 (mm)	2095	2260	2430	2645	2810
自由起升高度 Height-Free Lift	h2 (mm)	985	1150	1320	1535	1700